

45° FLANGED ARC™BEND

STANDARD
FLANGED FITTINGS
USE DUCTILE IRON
ANSI B16.5 CLASS
150 BOLT PATTERN.
SS OR EPOXY
COATED ARE ALSO
AVAILABLE

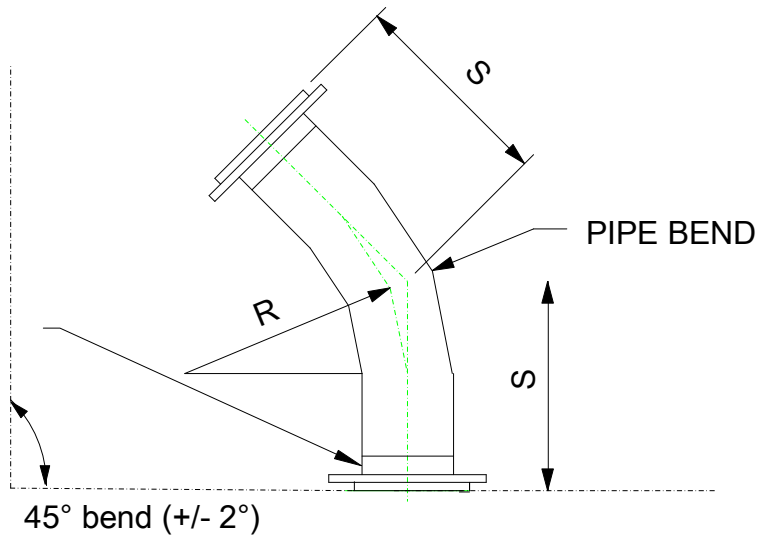

SIZE	R	S
2" IPS	7.13"	10.73"
3" IPS	10.50"	12.03"
4" IPS	13.50"	13.33"
6" IPS	19.90"	17.21"
8" IPS	24.50"	22.34"
10" IPS	32.25"	27.01"
12" IPS	38.30"	31.85"
14" IPS	38.90"	33.04"

- SPECIFICATIONS**
1. Bend is manufactured in one continuous piece of HDPE pressure pipe at the angle specified by the engineer, with an angular tolerance of $\pm 2^\circ$ without reversion.
 2. Center line radius of curvature generally 3 x outside diameter of the pipe. Meets Pipestar's published dimensional schedule. Dimensional tolerance $\pm \frac{3}{4}$ " (± 20 mm).
 3. Only ARC™bends as manufactured by Pipestar International Inc. will be considered approved. All others must submit technical data and samples to be considered for approval.

PIPESTAR INTERNATIONAL INC.

58 Paramount Road, Winnipeg, Manitoba, Canada

Phone (204) 949-3910, Fax (204) 949-3919

Email: info@arcbends.com